

Estimating N FLIGHT VISIBILITY

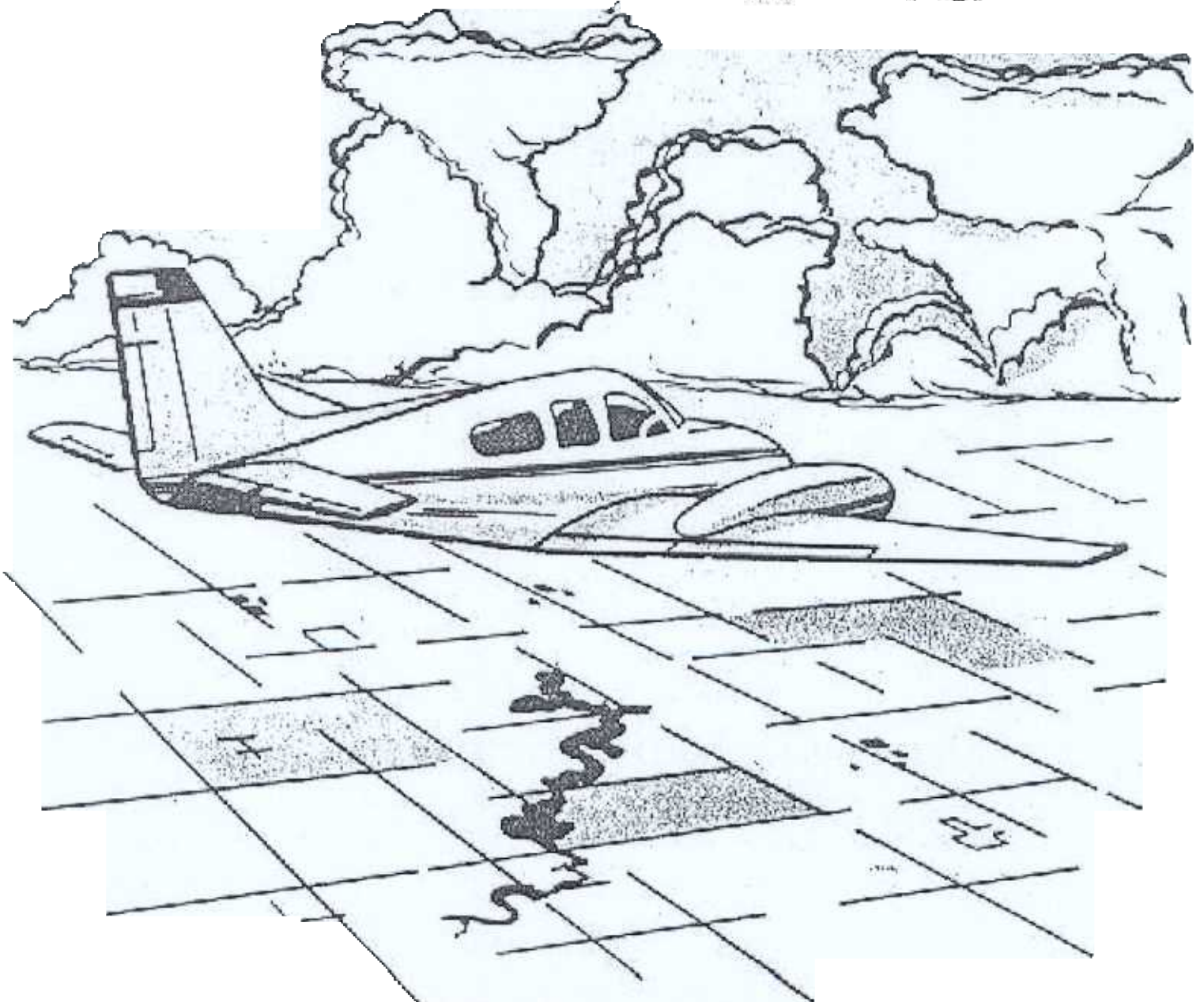



“CONTINUED FLIGHT INTO INSTRUMENT WEATHER CONDITIONS” – All too often this phrase is contained in the completed fatal accident report because the pilot did not have a “rule of thumb” to assist him in estimating in-flight visibility.

The material presented here is intended to provide the pilot with a “rule of thumb” guide only, to assist him in making his decision to land or continue, and does not reflect official FAA policy.

Remember! No words in any book can replace good judgment!

RULE OF THUMB

when surface is just visible over nose of aircraft the forward visibility will be approximately 1 mile for each 1000 feet altitude.

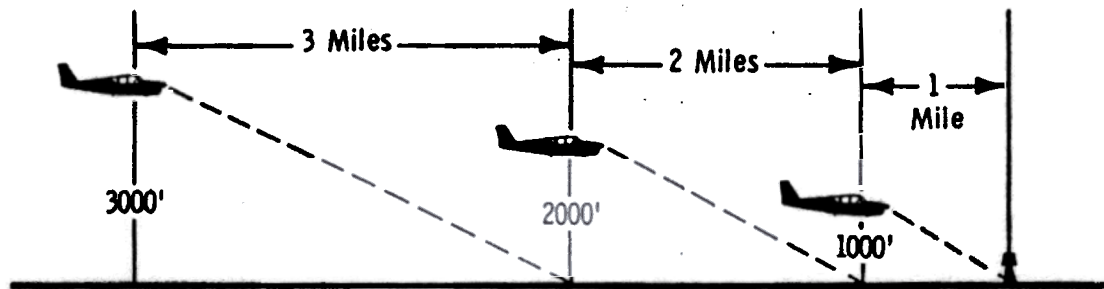

Figure 1. Rule of thumb

The Cockpit Cut-Off Angle and In-Flight Visibility. All too often, adequate visibility at the surface becomes marginal, or even below minimums at altitude, yet the VFR pilot may continue on his way simply because surface visibilities are reported at values comfortably above minimums. Some method of determining in-flight visibility with reasonable accuracy is, therefore, important. A rule of thumb (figure 1) which will not be equally accurate for all airplanes, but which is usually better than guessing is as follows:

The approximate visibility in miles will equal the number of thousands of feet above the surface when the surface is just visible over the nose of the airplane. In other words, at that point where the surface first appears over the nose of the airplane, your slant-range visibility will be approximately 2 miles if you are flying at 2,000 ft. above the surface. This rule of thumb is based on the cockpit cut-off angle. All airplanes do not have the same cut-off angle, therefore, the rule of thumb will not be equally accurate for all airplanes. As will be subsequently explained, the cockpit cut-off angle for any airplane can be determined rather easily. Once it is determined for a given airplane, it will remain constant as long as the eye level of the pilot is not changed. The steps in determining this cut-off angle on the ground are as follows (see figure 2).

HOW TO DETERMINE COCKPIT CUTOFF ANGLE AND ESTIMATE IN-FLIGHT VISIBILITY

1. Adjust the aircraft attitude as close as possible to the normal cruise pitch attitude.
2. Get in the pilot's seat and adjust it to the same position you would use in flight. Use your normal posture.
3. Measure the distance between the ground and your eye level. (Example 6 feet)
4. Look over the nose of the aircraft (cockpit cutoff angle) at the point where the ground surface is just visible. Measure this distance from directly under your eye position along the surface. (Example 30 feet)
5. **EXAMPLE:** Six (6) foot eye height, and thirty (30) foot distance.

$$\frac{6}{30} = .20; \quad .20 \text{ is the tangent value.}$$
6. Look on the list below for the nearest tangent value you computed and you will find the corresponding angle, which will be the cockpit cutoff angle for your aircraft.

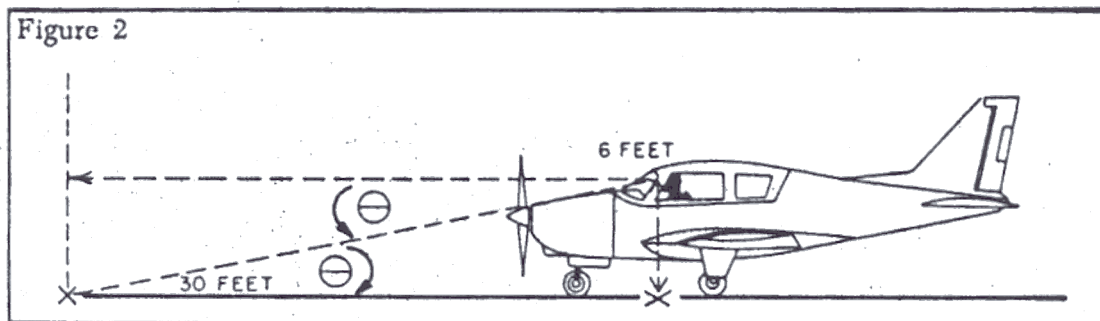

TANGENT VALUE	ANGLE	APPROXIMATE VISIBILITY AT 1000' AGL.
.052	3 degrees	19,200 feet
.070	4	14,280
.087	5	11,500
.105	6	9,530
.123	7	8,130
.141	8	7,090
.158	9	6,330
.176	10	5,750
.194	11	5,150
.213	12	4,710
.231	13	4,320
.249	14	4,010
.268	15	3,730
.287	16	3,480
.306	17	3,270
.325	18	3,070
.344	19	2,910
.364	20	2,750

NOTE: For 500' AGL visibility in feet would be approximately half of the 1000' value.

NOTE: Values in one mile.
 $\frac{1}{4}$ equals 1,320 feet
 $\frac{1}{2}$ equals 2,640 feet
 $\frac{3}{4}$ equals 3,960 feet
 1 equals 5,280 feet